



Bal du samedi 23 novembre 2019

- ***BETHANKIT (J8x32) 3C (4C set) Moira Stacey RSCDS Graded 3**

1- 8 1s set, cast (2s step up) and dance ½ Fig of 8 round 2s

9-16 1M+2s also 1L+3s dance reels of 3 across (1M+2M, 1L+3L pass LSh). 1s end in 2nd place opposite sides

17-24 1s set, turn ¾ RH, 1M with 2s (at top) also 1L with 3s (at bottom) dance LH across. 1s finish in 2nd place own sides

25-32 2s+1s R&L

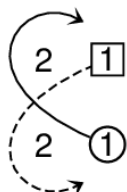
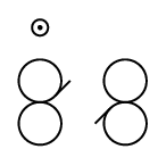
BETHANKIT					8x32 J
S 			1x S T _R ^{3/4}	2 ① ① 3 LA	2 1 RL

Moira Stacey, 2008, Footnotes 7, RSCDS Graded Book 3.2

3C/4C longwise set.

- ****BILL CLEMENT MBE (J8x32) 3C (4C set) John Wilkinson RSCDS Book 47**

1- 8 1s set and dance down between 3s and cast up to end LH with partner facing 1st corners

9-16 1s set and turn inwards to face 3rd corners, 1s set to 3rd corners and turn corners LH to end RH with partner facing 2nd corners

17-24 1s set and turn inwards to face 4th corners, 1s set to 4th corners and turn corners RH to end 2nd place own side

25-32 2s+1s+3s circle 6H round and back

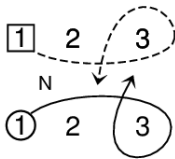
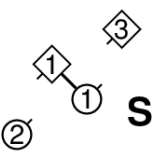
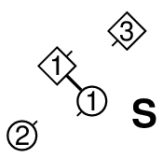
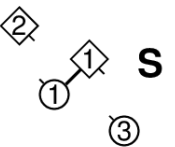
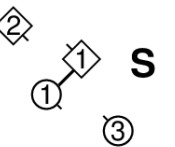
BILL CLEMENT MBE			8x32 J
S 			T _L
		T _R	2 1 3 ⑥

John Wilkinson, 2008, RSCDS Book 47.1

3C/4C longwise set.

- ****ADIEU MON AMI (S8x32) 3C (4C set) RSCDS Book 24**

1- 8 1s+2s set on sides, turn 2H, set to partners and turn 2H into Allemande hold

9-16 1s+2s Allemande 1s end facing 1st corners

17-24 1s dance 'Hello-Goodbye' setting, into middle facing partner, clap and petronella turn to 2nd place

25-32 2s+1s+3s circle 6H round and back

ADIEU MON AMI					8x32 S
$\boxed{1} - \boxed{2}$ $\textcircled{1} - \textcircled{2}$ S T_B	1 2 S T_B	1 2 A	\overline{S} S	× \overline{S} T _◇	2 1 3 $\textcircled{6}$

Button & Whitaker, 1814, RSCDS Book 24.11

3C/4C longwise set.







• ****THE TRI-MARINER (R8x32) 3C (4C set) Ann Dix Reel Friends 2**

1- 8 1s set, cast 2 places and lead up to top while 2s (bar 3) set, cast 1 place and lead up to 2nd place while 3s (bar 5) set, cast into middle

9-16 1s+2s+3s Promenade and end with 1s casting to 2nd place

17-24 1s cross down, cast up behind 3s, cross up and cast to 2nd place

25-32 All petronella turn into middle, set and turn partner RH 1¼ times

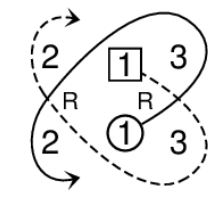
THE TRI-MARINER			8x32 R	
1: S   2: S   3: S  	1 2 3 PROM 		2 1 3 T_◇ S	2 1 3 T_R1¼

A Dix, 1993, Reel Friends 2, RSCDS Book 48.8

3C/4C longwise set.

• *****THE LIBRARY OF BIRMINGHAM (S4x40) 4C Kenneth J Reid RSCDS Book 49**

1- 8 1s+2s also 3s+4s dance Rose Progression:-

' 1- 2 1M+2L set as 1L+2M change places RH

' 3- 4 1M+2L ½ turn 2H as 1L and 2M dance into partner's place

' 5- 6 1M+2L cast into each other's place as 1L+2M ½ turn 2H

' 7- 8 1M and 2L dance into 2nd/1st places own side as 1L and 2M cast to right to new places

(3s+4s dance similarly)

9-16 All dance clockwise ½ way round set, all set. All ½ turn partner RH into Allemande hold

17-24 3s+4s also 1s+2s dance 6 bars of Allemande. All ½ turn LH to opposite sides. (Men face up, Ladies down)

25-32 All dance anticlockwise ½ way round set. 1s+2s also 3s+4s circle 4H round to Right. 1234

33-36 All 4 couples Set&Link with middle dancers linking 2 places; end dancers linking 1 place as follows:-

' 33-34 All set

' 35-36 1M dances down to 2nd place, 2M to 4th place, 3M casts up to 1st place, 4M to 3rd place while 1L casts to 2nd place, 2L to 4th place, 3L dances up to 1st place, 4L to 3rd place. 3142

37-40 3s+1s also 4s+2s circle 4H round to Left

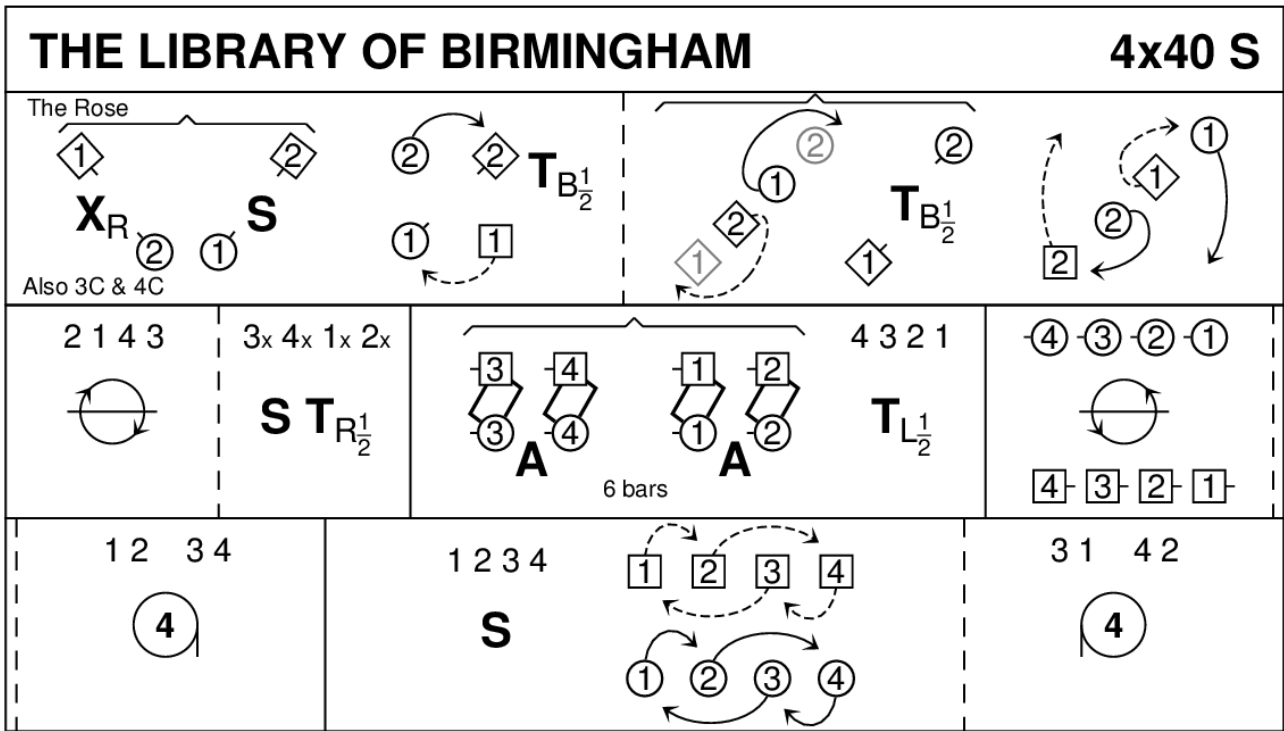

Kenneth J Reid, 2013, RSCDS Book 49.9

4C/4C longwise set.

• ***FLOWERS OF EDINBURGH (R8x32) 3C (4C set) RSCDS Book 1**

- 1- 8 1L followed by partner casts below 3s, 1L crosses and dances up behind Men as 1M dances up centre to 1st places on opposite side and 1s set
- 9-16 1M followed by partner repeat above Fig and set in own places
- 17-24 1s lead down the middle and back
- 25-32 1s+2s dance Poussette. 213

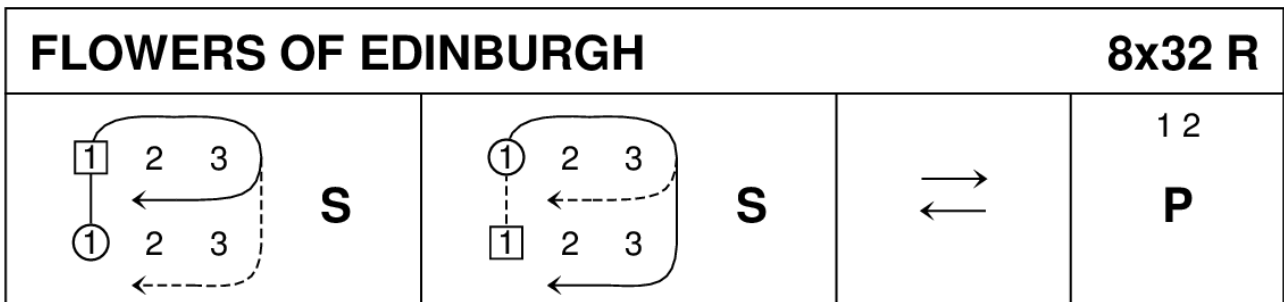

The Ballroom, 1827, RSCDS Book 1.6

3C/4C longwise set.

PAUSE

• ***EH3 7AF (J8x32) 3C (4C set) Roy Goldring RSCDS Book 40**

- 1- 8 1s lead down the middle and back to top
- 9-16 1s+2s+3s Promenade ending with 1s casting to 2nd place
- 17-24 1s pass by the right and turn 1st corners RH to end L between 2s and M between 3s, 1s pass by the right and turn 2nd corners RH to end between corners
- 25-32 1M dances RH across with 2s and 1L with 3s, 1L dances up between 2s and casts to 2nd place own side as 1M dances between 3s and casts up

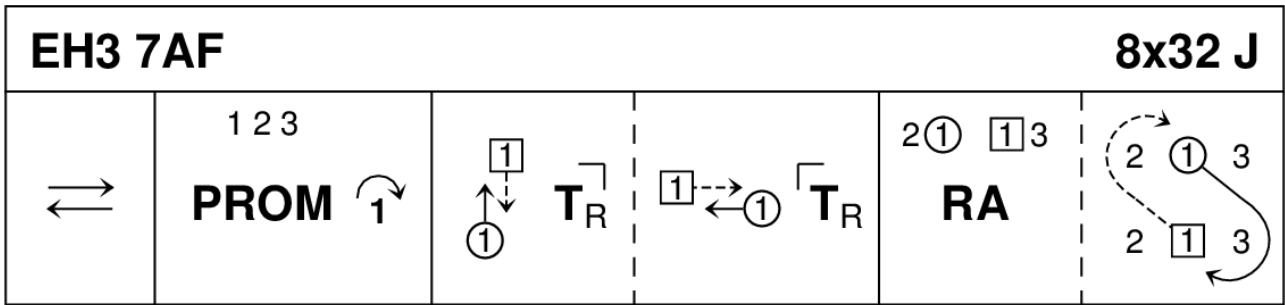

Roy Goldring, 1998, RSCDS Book 40.6

3C/4C longwise set.

• *****FORTY AND COUNTING (R8x40) 3C (4C set) Malcolm Brown Forty and Counting and RSCDS Book 52**

1- 8 1s set, cast (2s step up) and turn $1\frac{1}{4}$ LH to face 1st corners

9-16 1s dance Chain Progression for 3 couples on the diagonal:-

' 9-10 1s change places RH with 1st corners while 2nd corners chase 1 place clockwise

' 11-14 1st corners turn $1\frac{1}{2}$ LH in centre while 1s and 2nd corners promenade $\frac{1}{2}$ round (corners on outside)

' 15-16 2nd corners chase 1 place back to place while 1s change places RH with 1st corners. 1s end facing 4th corners

17-24 1s dance "Hello-Goodbye" setting ending facing 2nd corners

25-32 1s repeat Chain Progression for 3 couples with 2nd corners and end facing 1st corner positions

33-40 1s dance $\frac{1}{2}$ diagonal reel of 4 with 1st corners, pass RSh and dance $\frac{1}{2}$ diagonal reel of 4 with 2nd corners ending in 2nd place own side

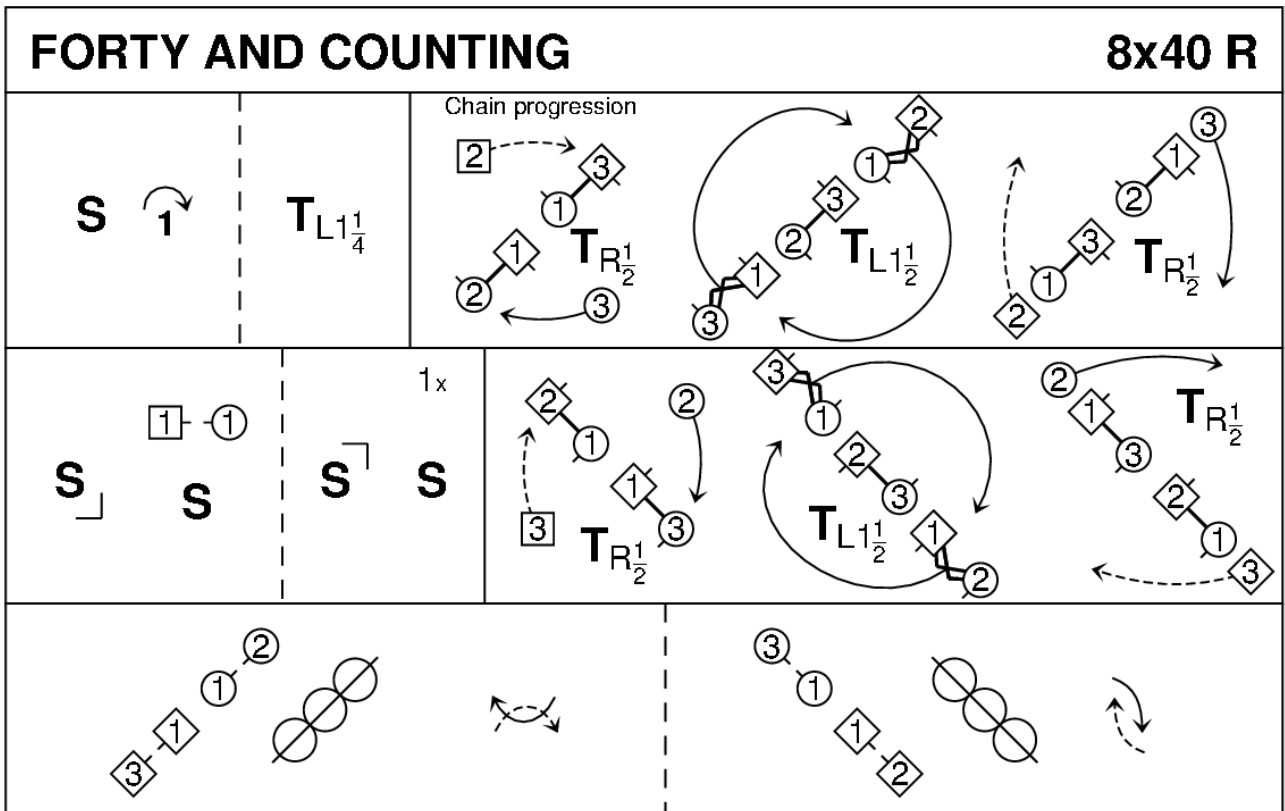

Malcolm Brown, 2015, RSCDS Book 52.4

3C/4C longwise set.

- ****STRATHGLASS HOUSE (S8x32) 3C (4C set) Robert Bremner RSCDS Book 13**

1- 8 1s+2s+3s set and circle 6H round ½ way, set and continue to circle 6H round back to place 9-16 1s Lead down below 2s, Cross&Cast down round 3s, lead up between to top and cast 1 place (on opposite sides) to face 1st corners

17-24 Turn 1st corner RH, partner LH, 2nd corner RH and partner LH to end in 2nd place opposite sides

25-32 2s+1s+3s Adv&Ret for 2 steps and 1s turn 2H 1½ times to own sides. 213

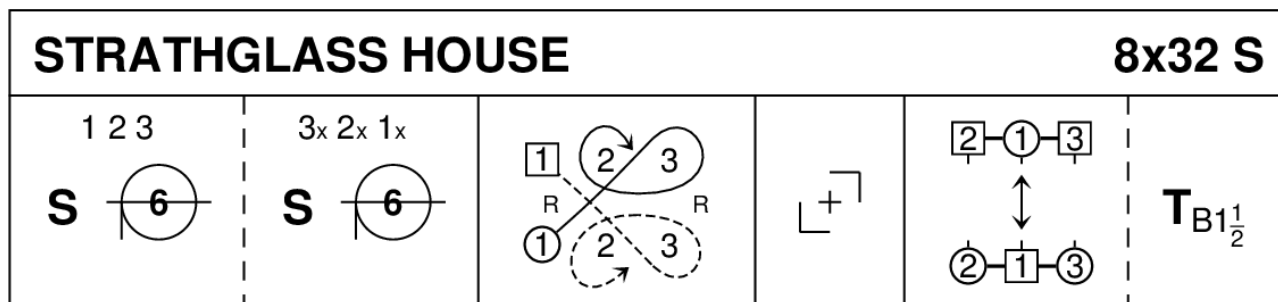

Robert Bremner, 1757, RSCDS Book 13.9

3C/4C longwise set.

- *****DOUBLE TROUBLE TRIANGLES (R4x48) 4C set Judith Kowalczyk RSCDS Book 50**

1- 8 1M+4L set, Adv&Ret and set while 1L+4M stand (2 bars), set, advance (2 bars) and set. (Bar 5 both couples join RH with partner and retain hands)

9-12 1s+2M and 4s+3L dance RH across, ending 2M in 1st place, 3L in 4th place

13-16 1s+2L and 4s+3M dance LH across, ending 1M behind 1L (above 1st place facing Men's side) 4L behind 4M (below 4th place facing Ladies' side), 2L in 1st place, 3M in 4th place

17-20 1L followed by 1M casts 2 places while 4M followed by 4L casts up 2 places. Bar 20: 1s+4s in line up/down middle BtoB with partner, Men facing up, Ladies down

21-24 4M+2s and 1L+3s circle 3H round to left while 4L+1M ½ turn LH, clap, ½ turn RH. 4s and 1s finish BtoB with partners

25-26 4M+2s and 1L+3s join hands (as 'Crown Triangles') and set while 4L+1M turn 2H ½ way (pas-de-basque)

27-28 4s+1s dance to Right (pas-de-basque) round person behind to change places while 2s+3s set

29-30 1M+2s and 4L+3s set (as 'Crown Triangles') while 4M+1L turn 2H ½ way (pas-de-basque)

31-32 1s and 4s dance to Right (pas-de-basque) round partner to centre facing up (Lady on Man's Left) while 2s+3s set

33-36 1s+4s lead up to top, cast on opposite sides, 1s to 3rd place, 4s to 2nd place

37-40 ½ Figs 8, 4s round 2s and 1s round 3s. 2413

41-48 All ½ turn partner RH, retain hands and set, release hands and pass partners RSh dancing out to own sides, all set

DOUBLE TROUBLE TRIANGLES			4x48 R

Judith Kowalczyk, 2014, RSCDS Book 50.8

4C/4C longwise set.

• ****MRS STEWART'S JIG (J8x32) 3C (4C set) Frans Ligtmans RSCDS Book 35**

1- 8 1s set, 1L followed by partner casts 2 places, 1L crosses (below 3s) and casts up on Men's side to 2nd place facing down while 1M dances round 3L and up the middle to 2nd place Ladies' side facing down

9-16 2s+1s+3s dance Grand Chain, end with 2M and 1M facing out

17-24 2s+1s dance Ladies' Chain

25-32 2s+1s+3s Adv&Ret for 2 steps and 1s turn 1½ RH to own sides

MRS STEWART'S JIG			8x32 J

Frans Ligtmans, 1986, RSCDS Book 35.1

3C/4C longwise set.

- ***THE DEIL AMANG THE TAILORS (R8x32) 3C (4C set) RSCDS Book 14**
 1- 8 1s+2s set and dance RH across ½ way, set and dance LH across ½ way back to place
 9-16 1s lead down the middle and back to top
 17-24 1s+2s dance Allemande
 25-32 2s+1s+3s circle 6H round and back. 213





THE DEIL AMANG THE TAILORS				8x32 R
$\overbrace{1\ 2}$ S RA	$\overbrace{2\times\ 1x}$ S LA	\rightleftarrows	$\overbrace{1\ 2}$ A	$\overbrace{2\ 1\ 3}$ 

Davies Collection, RSCDS Book 14.7

3C/4C longwise set.

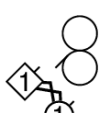
EXTRAS :



- ****PULLING BRACKEN (R8x32) 3C (4C set) Tony Bulteel SCD Archives**
 1- 8 1s in prom hold (Lady on Man's Left) dance reel of 3 across with 2s, passing 2L LSh to start. 1s end in 2nd place own sides, 2s dance up to 1st place
 9-16 2s+1s+3s dance Grand Chain (2s crossing at top)
 17-24 1s cross RH to face 1st corner and turn 1st corners LH, turn 2nd corners RH and ½ turn partner LH ready for...
 25-32 1L+2s and 1M+3s dance RH across, 1s pass RSh to dance LH across with other couple and 1s end in 2nd place own sides

PULLING BRACKEN				8x32 R
$\overbrace{1\ 2}$ 	$\overbrace{2\ 1\ 3}$ CHAIN 	$X_R\ T_L\ T_R\ T_{L\frac{1}{2}}$	 RA	 LA

Anthony Bulteel, SDA 68

3C/4C longwise set

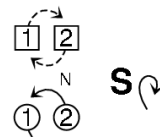
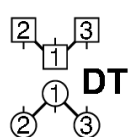
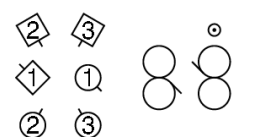
- ****THE STARRY EYED LASSIE (J8x32) 3C (4C set) Martin Sprague RSCDS Book 23**
 1- 8 1s+2s dance RH across; 1s cast down 1 place while 2s dance up to top, 1s set advancing, turning right about to end BtoB facing own sides for ready for...
 9-16 2s+1s+3s dance Double Triangles, ending with petronella turn to 1L between 2s and 1M between 3s facing 4th corners
 17-24 2s+1s+3s dance RSh reels of 3 across, 1s end in 2nd place opposite sides. 2(1)3
 25-32 2s+1s+3s circle 6H round to left (6 bars) and 1s cross RH to 2nd place own sides

THE STARRY EYED LASSIE				8x32 J
RA	 S	$\overbrace{2\ 1\ 3}$ DT 		$\overbrace{2\ 1\ 3}$  X_R 6 bars

Martin Sprague, RSCDS Book 23.11

3C/4C longwise set.