



# Bal du samedi 17 mai 2025

## 1. THE GOAT FELL GALLOP (J4x32) 4C set Roy Goldring G and S Dances 2

1- 8 1L+2L also 3M+4M cross passing partner by LSh and cast (Ladies down and Men up) to change places, repeat passing opposite person by the LSh

9-16 1M+2M also 3L+4L repeat bars 1- 8 but passing by RSh

17-24 1s slip step down the middle and up

25-32 1s cast to 4th place own sides and all turn partners LH

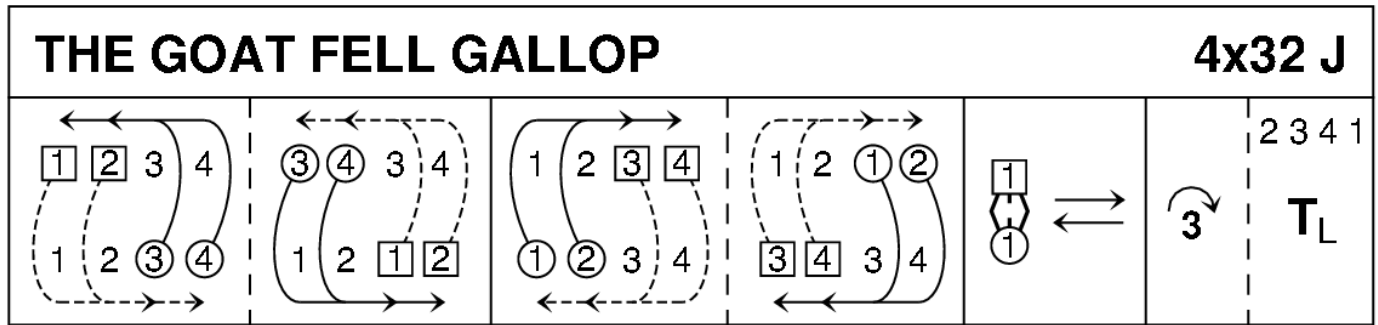

Roy Goldring, Graded and Social Dances 2

4C/4C longwise set.

## 2. SHIFTIN' BOBBINS (R8x32) 3C (4C set) Roy Clowes Ormskirk 6

1- 8 1s cross RH to double triangle position with 2s+3s and set, 1s cast up to top and dance down until they are between 2s and 3s

9-16 1L dances RH across with 2M+3M while 1M dances LH across with 2L+3L, 1s followed by 2s+3s dance down centre  
17-24 3s followed by 2s+1s dance up and 3s+2s cast down to places, 1L dances LH across with 2M+3M while 1M dances RH across with 2L+3L

25-32 1s dance up to top and cast down to 2nd place opposite side, 1s dance ½ Fig of 8 around 2s to end in 2nd place on own sides. 213

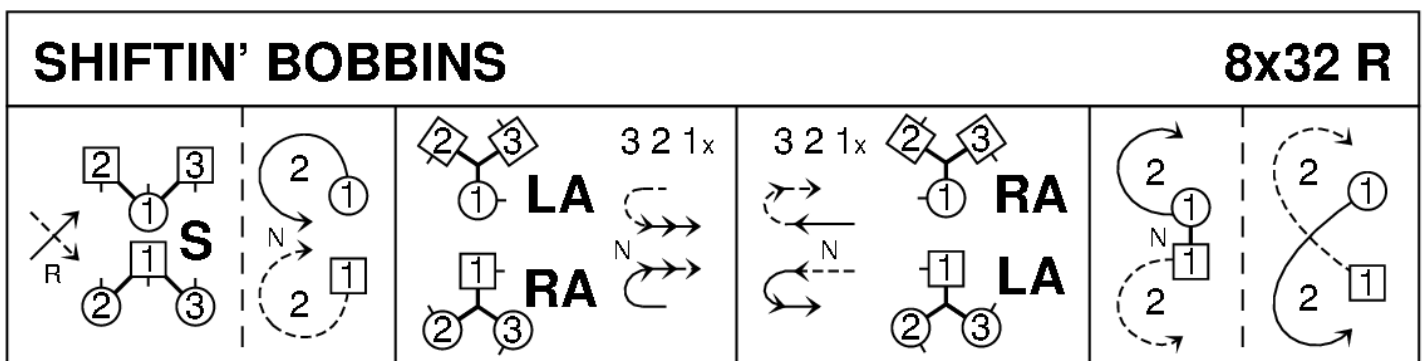

Roy Clowes, Ormskirk Book 6, RSCDS Thirty Popular Dances Vol 2

3C/4C longwise set.

## 3. MANOLIS'S MATHEMATICAL MANOEUVRES (J8x32) 3C (4C set) Manolis Debarre, Méaudre Reel 2024

1- 8 1s dance lead down and back

9-16 1s dance a long cast (2s step up), 1s turn RH 1½ and twirl, pulling back RSh to end facing 1st corners

17-24 1s dance Corners Pass and Turn with 1st corners and pass RSh to face 2nd Corners

1s dance Corners Pass and Turn with 2nd corners and pass RSh to end in 2nd place

25-32 1s dance Right Hand Across (1L with 2s at the top and 1M with 3s), 1s pass RSh and dance Left Hand Across with the other couple (1L with 3s and 1M with 2s)

4. **HAPPY EASTER WITH ANOUK (S32x8) 2C (4C set), Méaudre Reel 2024 Anouk Bagafu**

1-8 1s and 2s advance and retire (in 4 bars), 1s and 2s dance a Petronella Turn ending in the middle of the set, 1s and 2s turn partner Both Hands (in 2 bars)

9-16 1s and 2s dance a Reel of Four

17-24 1s and 2s dance a Petronella Turn finishing on opposite sides, 1M and 2M, 1L and 2L dance half turn Both hands to change places, 2s and 1s dance half Rights and Lefts

25-32 1s and 2s dance a Bourrel

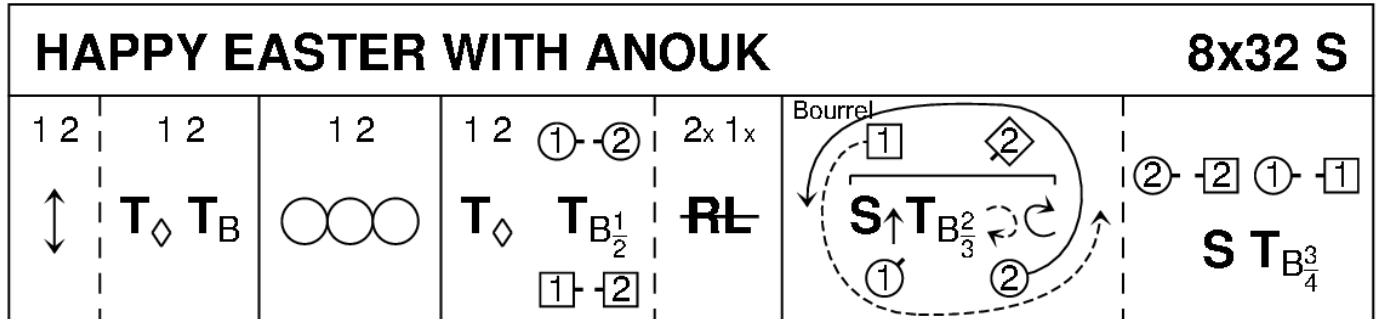

Anouk Bagafu, 2024

2C/4C longwise set.

5. **TEACHER'S CHOICE > Reel**

6. **THE DUNDEE WHALER (S4x32) 4C set Roy Clowes Ormskirk 1**

1- 8 2s and 4s dance ½ Petronella figure to opposite sides (petronella turn and set, twice)

9-16 1s+2s and 3s+4s dance Ladies' Chain

17-24 1s and 3s dance ½ Petronella figure to opposite sides (petronella turn and set, twice)

25-32 1s "zig-zag" to 4th place, 1L starting changing places diagonally LH with 2M:

1L+2M change places LH, 1M+2L also 1L+3L change places RH, 1M+3M also 1L+4M change places LH and 1M+4L change RH

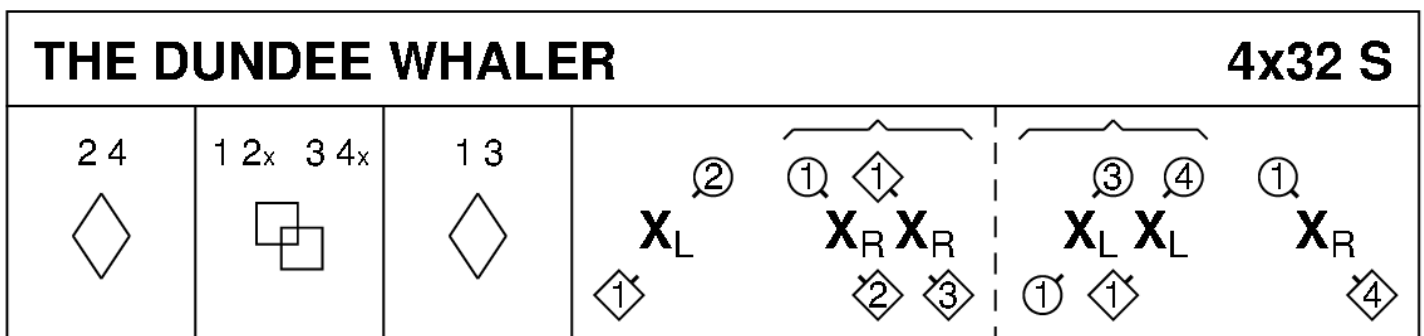

Roy Clowes, Ormskirk

4C/4C longwise set.

7. **PINEWOODS REEL (R8x32) 3C (4C set) John Bowie Dickson Yankee Sampler and RSCDS book 53**

1- 8 1s and 3s dance Figs of 8 round 2s (1s cast to start), 2s step up to top place and 1s end in 2nd place BtoB ready for Double Triangles

9-16 1s dance Double Triangles while corners set and petronella on 1 place to right, set and petronella on 1 more place as 1s end facing 3rd corner (position)

17-24 1s dance ½ diagonal reel of 4 with 3rd corners, pass RSh and repeat with 4th corners (position)

25-32 1L dances a reel of 3 across with 2s as 1M dances reel of 3 across with 3s both passing 1st corner LSh and 1s end turn RH to 2nd place on own side (facing out ready to cast)

PINWOODS REEL		8x32 R	
<p>Double Figure 8</p>	<p><b>DT ST</b> ◊</p>	<p><b>DT ST</b> ◊</p>	
			<p><b>T<sub>R</sub></b></p>

John Bowie Dickson, RSCDS Book 53, Yankee Sampler

3C/4C longwise set.

**8. THE BEES OF MAGGIEKNOCKATER (J4x32) 4C set John Drewry Canadian Book**

1- 8 1s cross RH and cast 1 place, dance RH across with 3s and end 1M+3L also 1L+3M in prom hold facing out to pass corner person RSh

9-24 All dance 4x½ Reels of 3 on sides (to right to start, then left, right and left) with 1s+3s changing partners in centre at end of each ½ Reel to progress Men clockwise and Ladies anticlockwise. End in centre 1s facing down and 3s facing up

25-32 1s dance between 3s turning 3s with nearer hand 1½ times, crossing over to own sides and turn 4th person 1½ times (Men RH and Ladies LH) 2341

THE BEES OF MAGGIEKNOCKATER		4x32 J	
<p><b>X<sub>R</sub> 1</b></p>	<p>1x 3</p> <p><b>RA</b></p>		
		<p>① <b>T<sub>L</sub>1½</b> ③</p> <p>① <b>T<sub>R</sub>1½</b> ③</p>	<p>① <b>T<sub>L</sub>1½</b> ④</p> <p>① <b>T<sub>R</sub>1½</b> ④</p>

John Drewry, 1975, Canadian Book, RSCDS Thirty Popular Dances Vol 2

4C/4C longwise set.

**BREAK**

**9. TOAST TO THE MOUSIES (R8X32) 3C (4C set) Sara Gratiot RSCDS book 53**

1- 8 1s dance in and cast 1 place (2s step up), dance down between 3s and cast up to 2nd place  
 9-16 2s+1L also 1M+3s dance RH across and 1s pass RSh to dance LH across with other couple, 1s end back to back in the middle (1M facing up, 1L down) facing 2s/3s (2s facing down, 3s up nearer hands joined)  
 17-20 All set, 2s and 3s make arches, dance down/up to meet as 1s dance under arches. Finish 1M in 1st place, 1L in 3rd place (facing down/up) and 2s and 3s back to back in middle nearer hands joined (2s facing up, 3s down).  
 21-24 All set, 2s and 3s making arches dance to ends and cast into reel while 1s dance under arch passing LSh and finish between end couple facing 1st corner  
 25-32 2s+1L also 1M+3s dance LSh reels across (2s+3s make loops into the reel) to end 213. All set

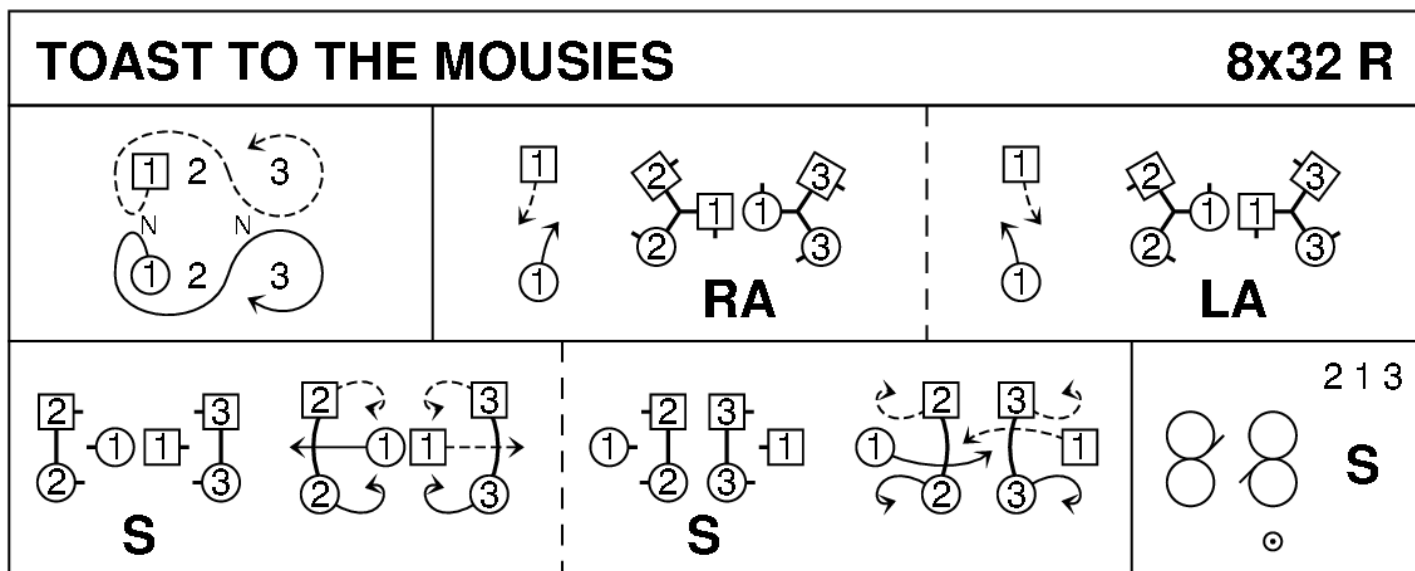

Sara Gratiot, 2016, RSCDS Book 53

3C/4C longwise set.

**10. ON DC'S ROADS (S4x32) 4C Set Aymeric Fromherz 2015 Paris Book of SCD vol 1**

1- 8 1s+2s also 3s+4s dance Diamond Poussette  
 9-16 2s+3s dance set and rotate:  
 Set, Rotate singly and dance on 1 place clockwise, change places RH on sides and dance on 1 place to own sides.  
 1324  
 17-20 3s+2s dance RH across to finish on sides while 1L and 4M followed by partners chase clockwise 1/2 way. (4)32(1)  
 21-24 4s+1s dance RH across to finish on sides (2nd and 3rd places) while 2L followed by 3L also 3M followed by 2M chase clockwise 1/2 way to finish. (2)(4)(1)(3)  
 25-32 All 1/2 turn partner RH, pull back RSh and dance out to own sides; 2s+4s and 1s+3s circle 4H round to left. 2413

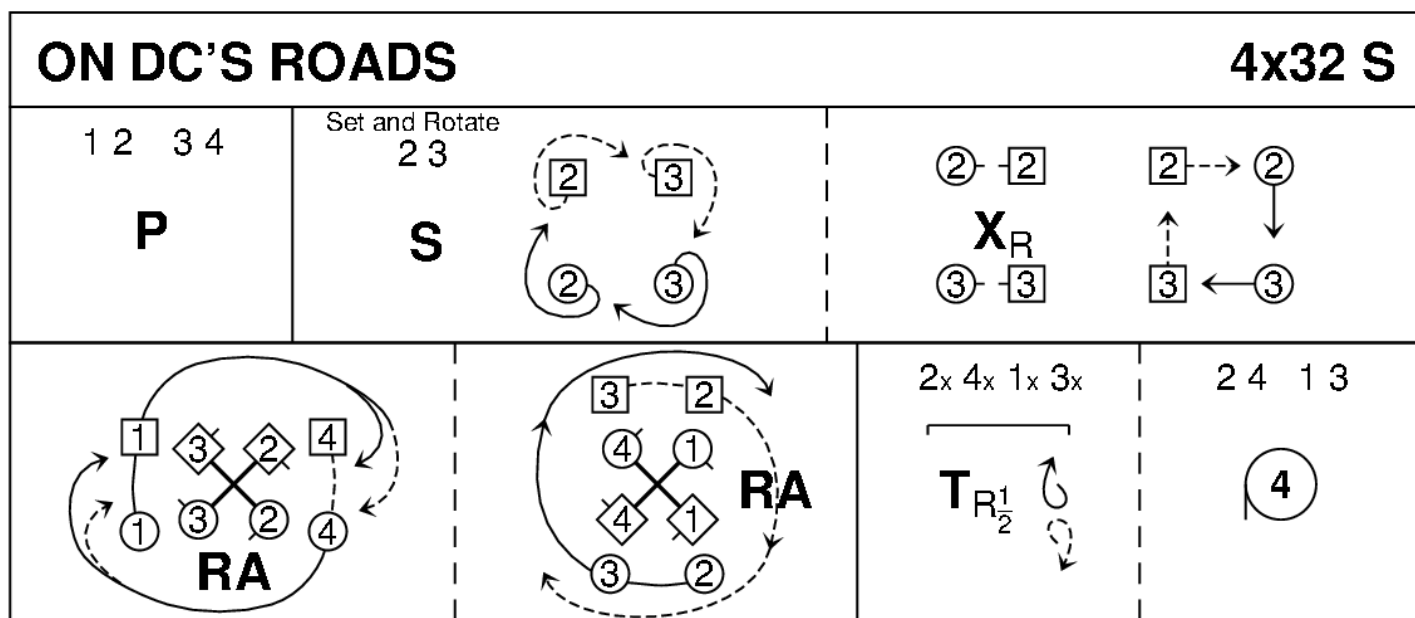

Aymeric Fromherz, 2015, Paris Book vol 1

4C/4C longwise set.

11. TEACHER'S CHOICE > Jig

12. A WEDDING IN DAUPHINE, (R4x32) 4C Martin Sheffield, 1999

1- 8 1s lead down between 3s, cross and cast up to 2nd place (2s step up on bars 3&4) , | 2s+1s+3s set  
 9-16 2s+1s+3s advance and retire; turn partner RH ½. 1s & 4s (who step in) face up, 2s & 3s face down, all set with near hands joined  
 17-24 2s & 3s dance down as 1s & 4s dance up making arches ; 1s & 3s change sides and direction turning under joined arms while 2s making arch dance down as 4s dance up ; 1s & 2s dance down as 4s & 3s dance up making arches ; 4cs & 2s change sides and direction turning under joined arms while 1s making arch dance down as 3s dance up  
 25-32 4s+3cs & 1s+2s dance 4 hands round to the left ; 4s & 1s ½ Fig8 down round nearest couples

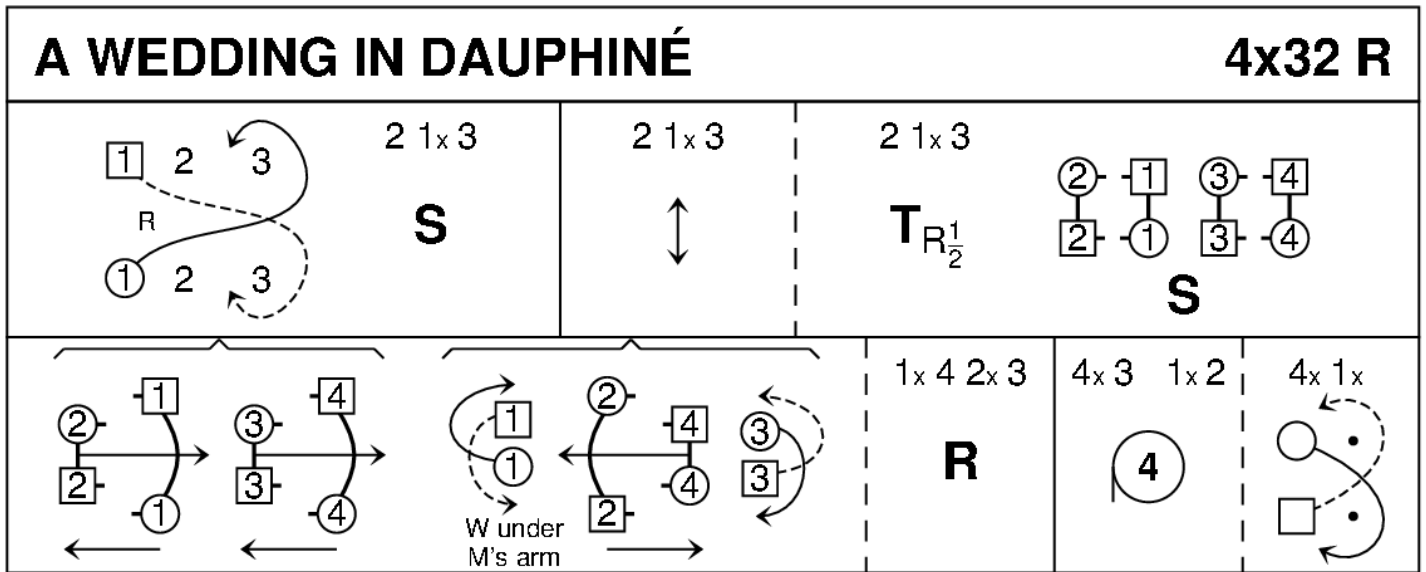

Martin Sheffield, 1999, 140 Scottish Country Dances

4C/4C longwise set.

13. ADIEU MON AMI (S8x32) 3C (4C set) RSCDS Book 24

1- 8 1s+2s set on sides, turn 2H, set to partners and turn 2H into Allemande hold  
 9-16 1s+2s Allemande 1s end facing 1st corners  
 17-24 1s dance 'Hello-Goodbye' setting, into middle facing partner, clap and petronella turn to 2nd place  
 25-32 2s+1s+3s circle 6H round and back

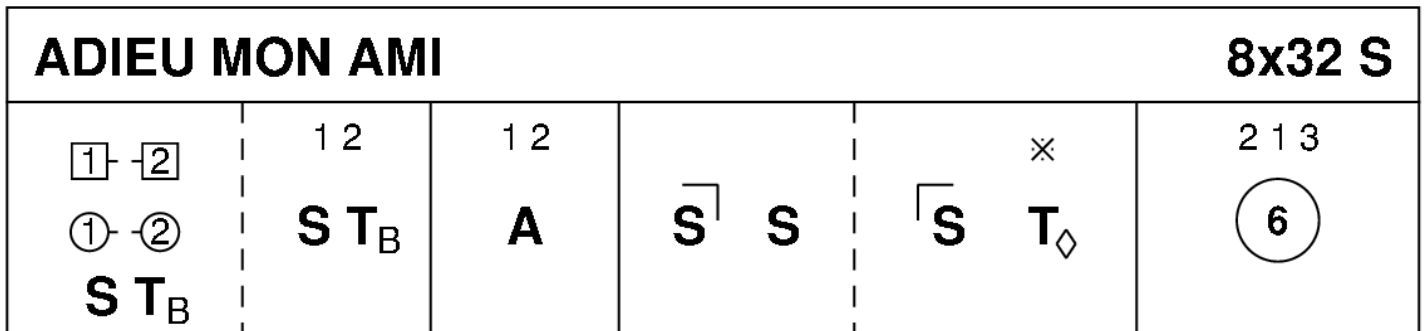

Button & Whitaker, 1814, RSCDS Book 24.11

3C/4C longwise set.

14. **THE WALNUT CAKE (J8x32) 3C (4C set) Anne Dejean Walnut Book**

1- 8 1s cross RH and cast (2s step up); 1s cross LH and set

9-16 1s dance diagonal R&L (Man down, Lady up) to end (3)1(2)

17-24 All advance and retire twice

25-28 All cross RH, 1s cast right into lines of 3 across (1L between 3s at top, 1M between 2s at bottom) while corners set facing up/down

29-32 All cross LH, 1s cast left to 2nd place on side while corners set to partners. 213

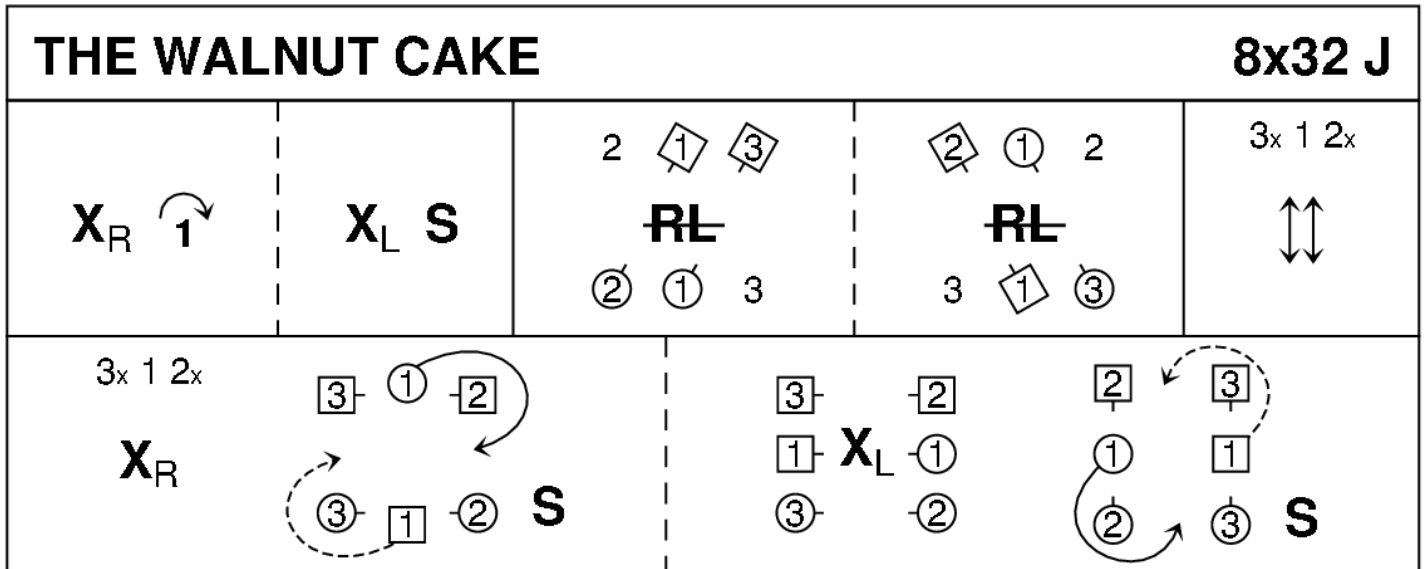

Anne Dejean, 2018, Walnut Book

3C/4C longwise set.

15. **THE DUKE AND DUCHESS OF EDINBURGH (R8x40) 3C (4C set) Allie Anderson And Florence Lesslie RSCDS Book 39**

1- 8 1s+2s+3s advance and retire and turn partners 2H

9-16 1s cast, lead down between 3s, cast up behind 3s, lead up between 2s and cast back to 2nd place (2s step up 15-16)

17-24 1s dance RH across (Lady with 2s and Man with 3s), pass RSh and dance LH across with other couple to end facing 1st corners

25-32 1s turn 1st corner, partner, 2nd corner and partner to own sides 2nd place

33-40 2s+1s+3s circle 6H round and back

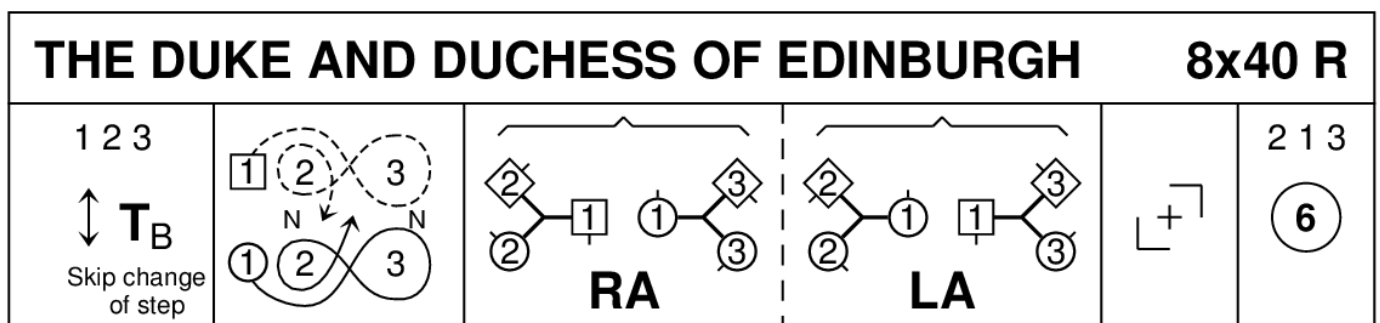

Allie Anderson & Florence Lesslie, 1947, RSCDS Book 39.7

3C/4C longwise set.