



Programme Bal stage galette 2023

1-BLOODY CATHETER (J4x32) 4C Anne Dejean, 2021

1 - 4 1st man, 2nd woman, 3rd man and 4th woman advance for 2 steps while their partners retire for 2 steps, then all dance back to place.

5 - 8 All chase clockwise halfway round.

9 - 16 Repeat bars 1 - 8 from these new positions.

17 - 24 1st and 2nd couples dance half rights and lefts, then 1st and 3rd couples dance half rights and left.

25 - 32 1st and 4th couples dance half rights and lefts, then all, giving right hands, turn partners one and a half times to finish on own sides in the order 2341.

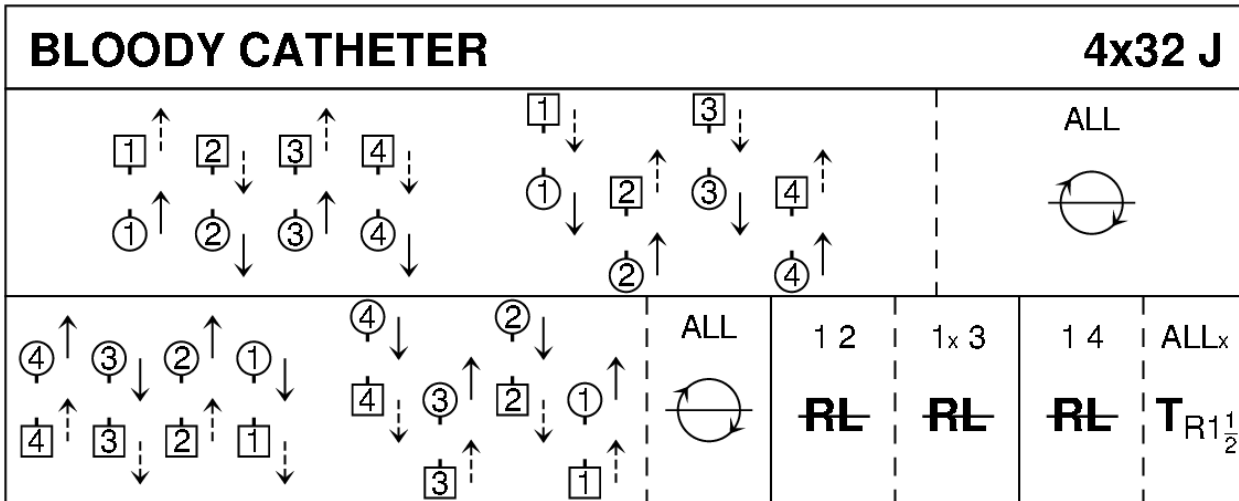

Anne Dejean, 2021, The Remission Book

4C/4C longwise set.

2-THE RUBY RANT (R8x32) 3C (4C set) Francis Walduck RSCDS Book 49

1- 8 1s+2s set, pull back RSh, dance 2 places clockwise, cross RH to own sides. 1s face out

9-12 2s+1s+3s dance ½ reels of 3 on sides (1M+2M also 1L+3L pass RSh) Bars 11-12: 1L (from 3L place) and 1M (from 1M place) dance across to 2nd place opposite sides and face out

13-16 3M+1L also 1M+2L turn RH

17-20 3s+1s+2s dance ½ reels of 3 on sides (1L+2M also 1M+3L pass LSh) Bars 19-20: 1L (from 3M place) and 1M (from 1L place) dance across to 2nd place own sides and face out

21-24 2L+1L also 1M+3M turn LH, 1s passing LSh to BtoB facing opposite sides (2L+3M dance 4 bars)

25-32 2s+1s+3s set as Double Triangles. All set again as 1s turn right about to face and turn RH 1½ to 2nd place own sides

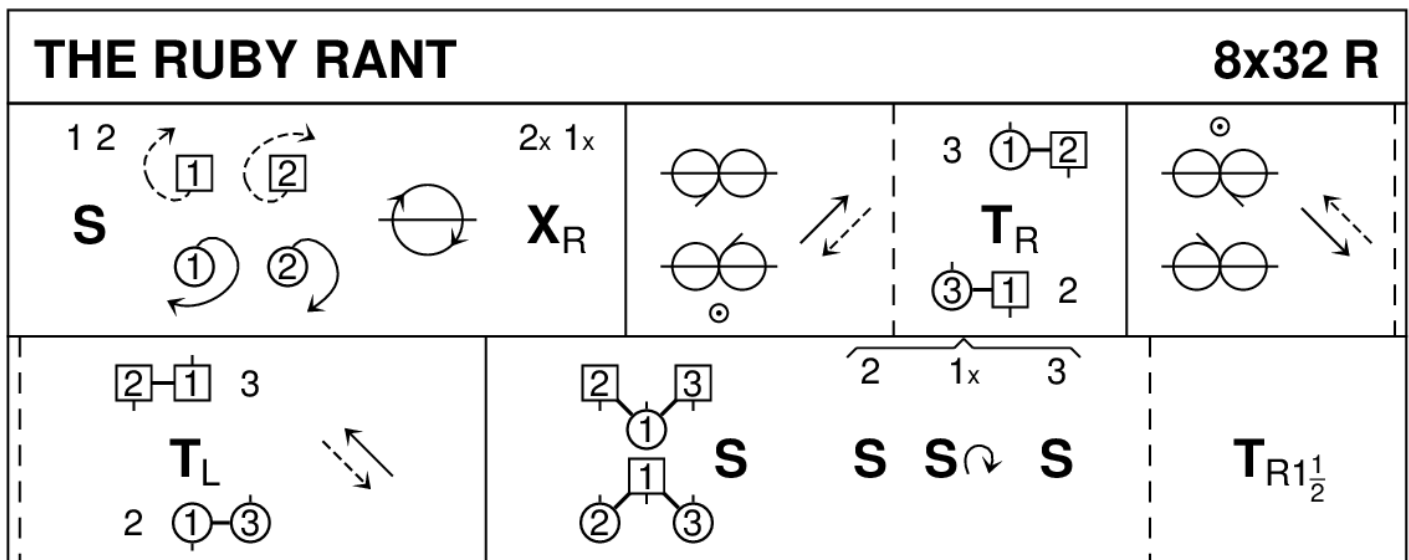

Francis Walduck, 2013, RSCDS Book 49.6

3C/4C longwise set.

3-MISS ELEANOR (S3x32) 3C Ann Dix RSCDS Book 49

1- 8 1s+2s+3s dance Mirror (Reflection) reels of 3 on sides (1s in/down to start)

9-16 1s set, cast (2s step up) and turn RH. 1L casts to 3rd place, 1M casts up to 1st place (2M steps down and 3L steps up)

17-24 All dance 3 couple Bourrel:

17-20 1M+3L also 2M+1L set advancing and $\frac{3}{4}$ turn 2H to line up/down middle then pull back RSh turning to face own partners as 3M and 2L chase anticlockwise to face them

21-24 All set and turn 2H to own sides. 312

25-32 3s+1s+2s circle 6H round and back

MISS ELEANOR			3x32 S		
	S	T_R			
Bourrel		S T_{B_{3/4}}	3 1 2 		

Ann Dix, 2013, RSCDS Book 49.5

3C/3C longwise set.

4-GAELFORCE WIND (J8x32) 3C (4C set) Derek Haynes Carnforth Collection 3

1- 8 1s set, cross RH, 1s+2s set and link (Ladies face out)

9-16 2s+1s Men's Chain

17-24 1s $\frac{1}{2}$ Figs of 8 (L round 2s and M round 3s), 2s+1s+3s turn RH and open into

25-32 2s+1s+3s circle 6H round and back

GAELFORCE WIND				8x32 J	
S X_R	1x2 S & LINK	2 1x 		2 1 3 T_R	2 1 3

Derek Haynes, 1996, Carnforth Collection 3, RSCDS Graded Book 3.12

3C/4C longwise set.

5-TEACHER'S CHOICE > Reel



6-MISS OGILVIE'S FANCY (S8x32) 3C (4C set) William Campbell RSCDS Book 20

1- 8 1s+2s dance Diamond Poussette

9-16 1s lead down the middle for 3 steps, back to top and cast to 2nd place

17-24 1s+3s circle 4H round and back

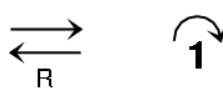
25-32 2s+1s dance R&L

MISS OGILVIE'S FANCY			8x32 S
1 2 P		1 3 	2 1 RL

William Campbell, 1789, RSCDS Book 20.8

3C/4C longwise set.





7-EH3 7AF (J8x32) 3C (4C set) Roy Goldring RSCDS Book 40

1- 8 1s lead down the middle and back to top

9-16 1s+2s+3s Promenade ending with 1s casting to 2nd place

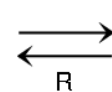
17-24 1s pass by the right and turn 1st corners RH to end L between 2s and M between 3s, 1s pass by the right and turn 2nd corners RH to end between corners

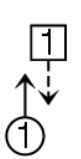
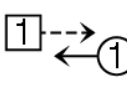
25-32 1M dances RH across with 2s and 1L with 3s, 1L dances up between 2s and casts to 2nd place own side as 1M dances between 3s and casts up

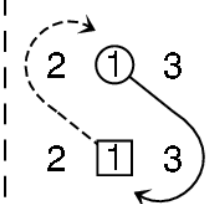
EH3 7AF					8x32 J
	1 2 3 PROM 	 T _{R^{3/4}}	 T _{R^{3/4}}	RA 	

Roy Goldring, 1998, RSCDS Book 40.6

3C/4C longwise set.

PAUSE





8-GRANVILLE MARKET (J8x32) 3C (4C set) Elinor M Vandegrift 2nd Graded Book SCDs

1- 8 1s+2s dance RH across and LH back

9-16 1s cross RH and cast 1 place. 1s dance 1/2 Fig of 8 round 2s and end facing 1st corners

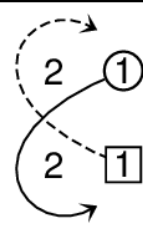
17-24 1s turn corners RH and pass RSh to face 2nd corners, 1s turn 2nd corners RH and pass RSh to end 2nd place own sides

25-32 2S+1s+3s circle 6H round and back

GRANVILLE MARKET					8x32 J	
1 2 RA	1 2 LA	X _R 		T _R 	T _R 	2 1 3 

Elinor M Vandegrift, RSCDS Graded Book 2.18

3C/4C longwise set.

9-THE SNOW WAVE (R4x40) 4C, Méaudre Reel 2021

Devised by Manon Le Duc, Lise Marchand and Lilia Mélé Angevin

1-8 1s+4s dance Petronella turn into centre, set to partner, finishing in a line up and down in middle of the set

1s+4s dance half RSh Reel of 4 up and down on midline

9-16 1s+4s dance Petronella turn and set to partner, finishing 4231

2s+3s dance half RH across and set, finishing 4(3)(2)1

17-24 3s+2s dance set and rotate, finishing 4(2)(3)1

25-32 4s+1s set, turn RH (2 bars), twirl and set to partner

while 3s+2s set, half turn RH (2 bars), twirl and set (advancing on 2nd PdB), finishing 4231 ready for

33-40 4s+2s and 3s+1s dance poussette, finishing 2413

THE SNOW WAVE				4x40 R
$\overbrace{1\ 4}$ T \diamond S	$1\ 4$ 	$\overbrace{4\ 1}$ T \diamond S	$\overbrace{2\ 3}$ RA S	Set and Rotate $3 \times 2 \times$ S
 X_R		$4\ 2 \times 3 \times 1$	$\overbrace{4\ 2 \times 3 \times 1}$ S T_R T_R¹/₂ T_R	$\overbrace{4\ 2\ 3\ 1}$ S
				$4\ 2\ 3\ 1$ P

M Le Duc, L Marchand & L Angevin, 2021, Méaudre Reel Book 1

4C/4C longwise set.

10-THE ENCHANTED GARDEN (S8x32) 3C (4C set) Iain Boyd World Around the Corner

1- 8 1s turn RH, cast 1 place, passing LSh dance RSh round 1st corner to end 2nd place in centre facing opposite sides

9-16 1L+2s dance also 1M+3s dance RH across, 1s pass RSh and dance LH across with other couple 1s end 2nd place own sides

17-24 2s+1s+3s set, 1/2 turn 2H and twirl to opposite sides and cross back RH

25-32 2s+1s+3s circle 6H round and back

THE ENCHANTED GARDEN				8x32 S
T_R 1		$2\ \overline{1}\ \overline{1}\ 3$ RA	$2\ \overline{1}\ \overline{1}\ 3$ LA	$\overbrace{2\ 1\ 3}$ S T_B¹/₂ X_R

Iain Boyd, 1986, The World Around the Corner

3C/4C longwise set.

11-THE SOMERSET CHILDREN'S REEL (R8x32) 3C (4C set) Elizabeth Beckinsale 2015 RSCDS Book 51

1- 8 1s+2s dance RH across, LH back

9-16 1s lead down (2 steps), retain RH and set to each other, lead up to top and cast (2s step up 15-16)

17-24 1s+3s dance Double Fig of 8 (1s cross down, 3s dance up to start)

25-32 2s+1s+3s circle 6H round and back

THE SOMERSET CHILDREN'S REEL				8x32 R	
1 2 RA	1 2 LA	\xrightarrow{R} S	\xleftarrow{R} 1	 DOUBLE FIGURE EIGHT ① ③	2 1 3 6

Elizabeth Beckinsale, 2015, RSCDS Book 51

3C/4C longwise set.

12-TEACHER'S CHOICE > Strathspey

13-MUIRLAND WILLIE (J8x32) 3C (4C set) RSCDS Book 21

1- 4 1s lead down middle and cross over to cast up to 2nd place while 2s set and cross RH to 3rd place while 3s cast up to 1st place and cross RH

5- 8 All set and ½ turn 2H to own side

9-16 Repeat bars 1- 8 from new positions

17-24 1s lead up to 1st place (4 bars); 1s set (2 bars) then 1s+2s set advancing ready for...

25-32 1s+2s dance Poussette. 213

MUIRLAND WILLIE				8x32 J			
$\overbrace{1}$ X	$\overbrace{2}$ S	$\overbrace{3}$ X_R	3x 1x 2x S T_B¹/₂	3 1 2 R	$\overbrace{2}$ 	1 2 S S_↑	1 2 P

RSCDS Book 21.9

3C/4C longwise set.

14-THE DEIL AMANG THE TAILORS (R8x32) 3C (4C set) RSCDS Book 14

1- 8 1s+2s set and dance RH across ½ way, set and dance LH across ½ way back to place

9-16 1s lead down the middle and back to top

17-24 1s+2s dance Allemande

25-32 2s+1s+3s circle 6H round and back. 213

THE DEIL AMANG THE TAILORS

8x32 R

$\overbrace{1\ 2}$ S RA	$\overbrace{2x\ 1x}$ S LA	\rightleftarrows	$1\ 2$ A	$2\ 1\ 3$ 6
-----------------------------------	-------------------------------------	--------------------	--------------------	-----------------------

Dale's Collection, 1799, RSCDS Book 14.7

3C/4C longwise set.