



# Programme Bal stage galette 2025

## 1- LA NOIX DE GRENOBLE (R4x32) 4C Set Anne Dejean Walnut Book

1- 8 1s+2s also 3s+4s dance RH across and LH across back to place

9-16 1M+2L also 3M+4L turn RH; 1L+2M also 3L+4M turn RH

17-24 1s slip step down middle (4 bars) and slip back up (2 bars) to finish in 4th place own side (2s+3s+4s step up 21-22), All clap 4 times

25-32 All circle 8H round and back. 2341

LA NOIX DE GRENOBLE			Kids in the Alps	4x32 R
1 2 3 4 <b>RA</b> <b>LA</b>				2 3 4 1 

Anne Dejean, 2012, Walnut Book

4C/4C longwise set.

## 2- HAPPY EASTER WITH ANOUK (S32x8) 2C (4C set), Méandre Reel 2024 Anouk Bagafu

1-8 1s and 2s advance and retire (in 4 bars), 1s and 2s dance a Petronella Turn ending in the middle of the set, 1s and 2s turn partner Both Hands (in 2 bars)

9-16 1s and 2s dance a Reel of Four

17-24 1s and 2s dance a Petronella Turn finishing on opposite sides, 1M and 2M, 1L and 2L dance half turn Both hands to change places, 2s and 1s dance half Rights and Lefts

25-32 1s and 2s dance a Bourrel

HAPPY EASTER WITH ANOUK					8x32 S	
1 2 	1 2 <b>T</b> <sub>◇</sub> <b>T</b> <sub>B</sub>	1 2 	1 2 ①-② <b>T</b> <sub>◇</sub> <b>T</b> <sub>B<sup>1</sup>/<sub>2</sub></sub> 	2x 1x <b>RL</b>		

Anouk Bagafu, 2024

2C/4C longwise set.



## 3- LA VILLE LUMIERE (R32x4) 4C set, Nicolas "Niols" Jeannerod, 2019, Paris Book Vol 2

1-8 1s and 4s set and cast one place, as 2s&3s step out; 1s&4s dance RH across, 1M (4M following) & 4L (1L following) facing 3rd corners

9-16 *Dolphin Corners Pass and Turn* with lead change: same as Corners Pass and Turn except dancing couples change lead on [bar 10], pass RSh to face new leader's 4cnrs. Dancing couples change lead on [bar 14] and finish, 1s in 2pl centre & 4s in 3pl centre, both hands joined with partner (2,1,4,3)

17-24 1s&4s dance a Poussette

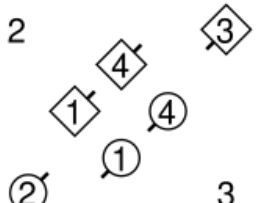
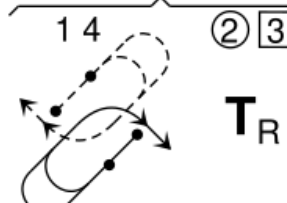
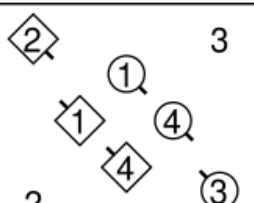
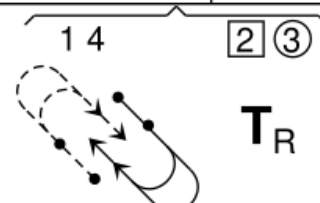
25-32 All circle 8 hands round and back (2,4,1,3)

<b>LA VILLE LUMIÈRE</b>		<b>4x32 R</b>	
1 4    1    4 <b>S</b> 1    1	1 4 <b>RA</b>	Dolphin Corners Pass & Turn    2 	1 4    ② ③ <b>T<sub>R</sub></b> 
 <b>T<sub>R</sub></b>	1 4    ② ③  <b>P</b>	2 4 1 3 	2 4 1 3 

Nicolas "Niols" Jeannerod, 2019, Paris Book Vol 2 4C/4C longwise set.

**4- TEACHER'S CHOICE > strathspey**

**5- SEE YOU IN BRITTANY(J32x8) 3C (4C set), Gilbert Bibard, Méaudre Reel 2024**

- 1- 4 1s cross Right Hand and cast off one place (2s step up on bars 3+4)
- 5- 8 1s turn Right Hand (in 4 bars), finishing in 2nd place (opposite sides) facing out while 2s and 3s change places Right Hand and set
- 9-16 3s and 1s and 2s dance a Right Shoulder Reel of 3 on sides, 1L starting giving RSh to 3M and 1M giving RSh to 2L, finishing 1L between 2s and 1M between 3s (at the top)
- 17-24 All 3 couples dance set and link, finishing on opposite sides (312) All 3 couples dance half chase clockwise (213)
- 25-32 1s dance Right Hand Across (1L with 2s at the top and 1M with 3s), 1s pass RSh and dance Left Hand Across with the other couple (1L with 3s and 1M with 2s)

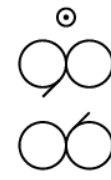
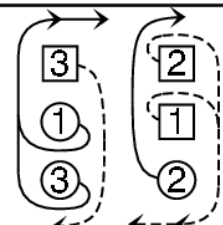
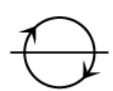
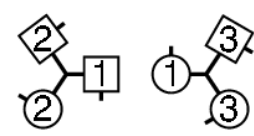
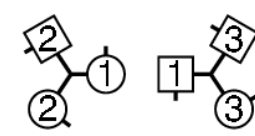
<b>SEE YOU IN BRITTANY</b>		<b>8x32 J</b>	
<b>X<sub>R</sub></b> 1	② ① ③ <b>X<sub>R</sub> S</b> <b>T<sub>R</sub></b> ② ① ③ <b>X<sub>R</sub> S</b>		Set and Link for Three ③ ① ③    ② ① ② <b>S</b> 
3x 1x 2x 	 <b>RA</b>	 <b>LA</b>	

Gilbert Bibard, 2024

3C/4C longwise set.

**6- EVERYTHING STOPS FOR TEA (London 1930-4PM) (S8x32) 3C (4C set) Ronald MacKay**

- 1- 8 2s followed by 1s lead down, 1s followed by 2s lead up to top and 1s cast to 2nd place
- 9-16 2s+1s+3s dance Grand Chain
- 17-24 1s dance ½ Fig of 8 round 3s (giving RH) and ½ Fig of 8 round 2s (giving RH)
- 25-32 1s dance RH across (Lady with 2s and Man with 3s) and dance LH across with other couple

EVERYTHING STOPS FOR TEA				8x32 S	
1 2 1 2 	<p><b>CHAIN</b></p>			2 1 1 3 <p><b>RA</b></p>	2 1 1 3 <p><b>LA</b></p>

Ronald Mackey, 2005, <http://www.strathspey.org/lists/strathspey%40strathspey.org/t/40340/>

3C/4C longwise set.

**7- THE CRAVEN TWELVESOME (R4x32) Sq.Set Derek Haynes Carnforth Collection 5**

**Man+2 Ladies per side of square set**

1- 8 All dance RSh reels of 3 with partners

9-16 All Men set, 1/2 RH across, dance out through opposite Ladies and cast to right to middle of next side Ladies

17-24 Top and bottom trios (side Men with new partners) advance, Ladies 1/2 turn 2H opposite Lady and retire with new partners, side trios repeat

25-32 All circle 12H round and back

THE CRAVEN TWELVESOME		Square set, 4M & 8L	4x32 R
		<p><b>S RA</b></p>	
2 3 2 	<p><b>T<sub>B</sub><sup>1/2</sup></b></p>	<p><b>R</b></p>	

Derek Haynes, Carnforth Collection 5

4T/4T square set.

**PAUSE**

**8- FLOWERS OF EDINBURGH (R8x32) 3C (4C set) RSCDS Book 1**

1- 8 1L followed by partner casts below 3s, 1L crosses and dances up behind Men as 1M dances up centre to 1st places on opposite side and 1s set

9-16 1M followed by partner repeat above Fig and set in own places

17-24 1s lead down the middle and back

25-32 1s+2s dance Poussette. 213

FLOWERS OF EDINBURGH			8x32 R
<p><b>S</b></p>	<p><b>S</b></p>	<p><b>R</b></p>	1 2 <p><b>P</b></p>

Hughes, 1867, RSCDS Book 1.6

3C/4C longwise set.

9- TEACHER'S CHOICE > Jig

10- CELINE AND FRIENDS (S32x4) 4C Sq.Set Colin Anderson 2023

1- 4 All set and turn partner RH

5-8 1s+3s dance halfway clockwise

while 2s+4s dance LH across to end longwise 3L3M/4M2L/4L2M/1M1L ready for

9-16 All dance RSh Reel of 4

17-20 Set with opposite person and turn this opposite person RH

21-24 1s+3s dance halfway clockwise

while 2s+4s dance LH across to end back in a square position

25-32 All dance half a Grand Chain to end in opposite starting positions ; all turn RH into promenade hold and dance 1 place clockwise

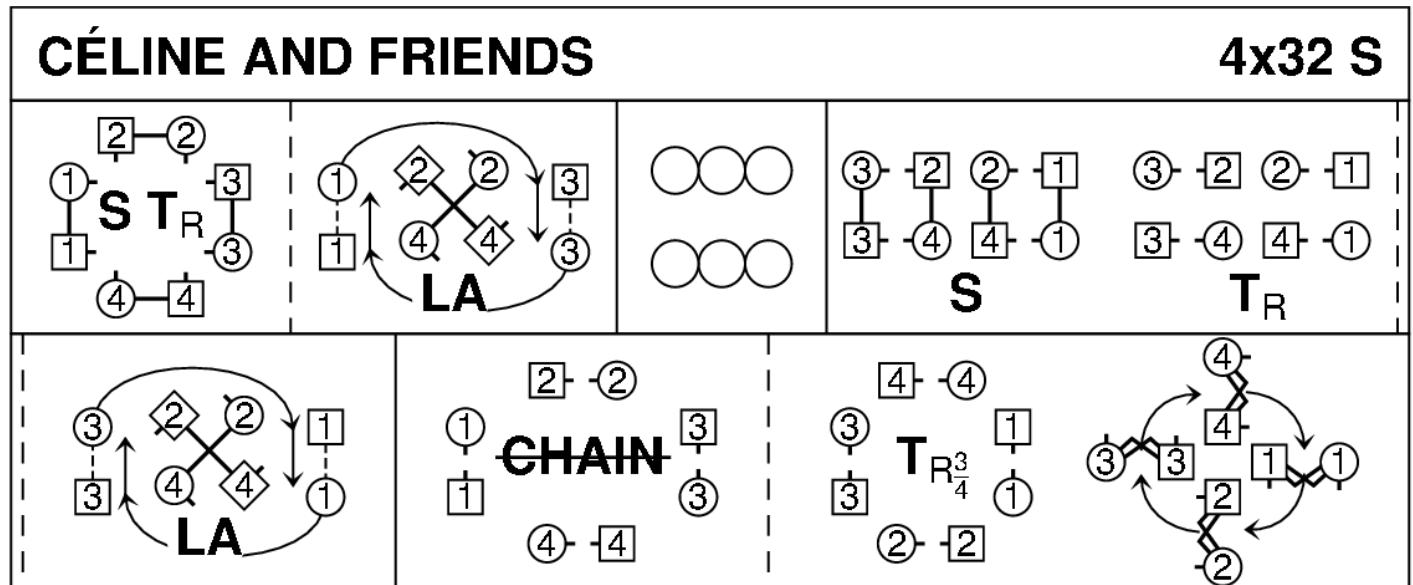

Colin Anderson, 2023

4C/4C square set.

11- POSTIE'S JIG (J4x32) 4C set Roy Clowes Ormskirk 5

1- 8 1s and 4s set and cast in 1 place, 1s and 4s dance 1/2 Figs of 8 round new end couples

9-12 1M+4M and 1L+4L cross (Men making an arch) and turn corners with free hand to face up/down

13-16 1s+4s dance down/up (couple dancing up make the arch) and turn corners

17-24 Repeat bars 9-16 from new positions

25-32 1s+4s dance 1/2 R&L, turn partner RH. 2413

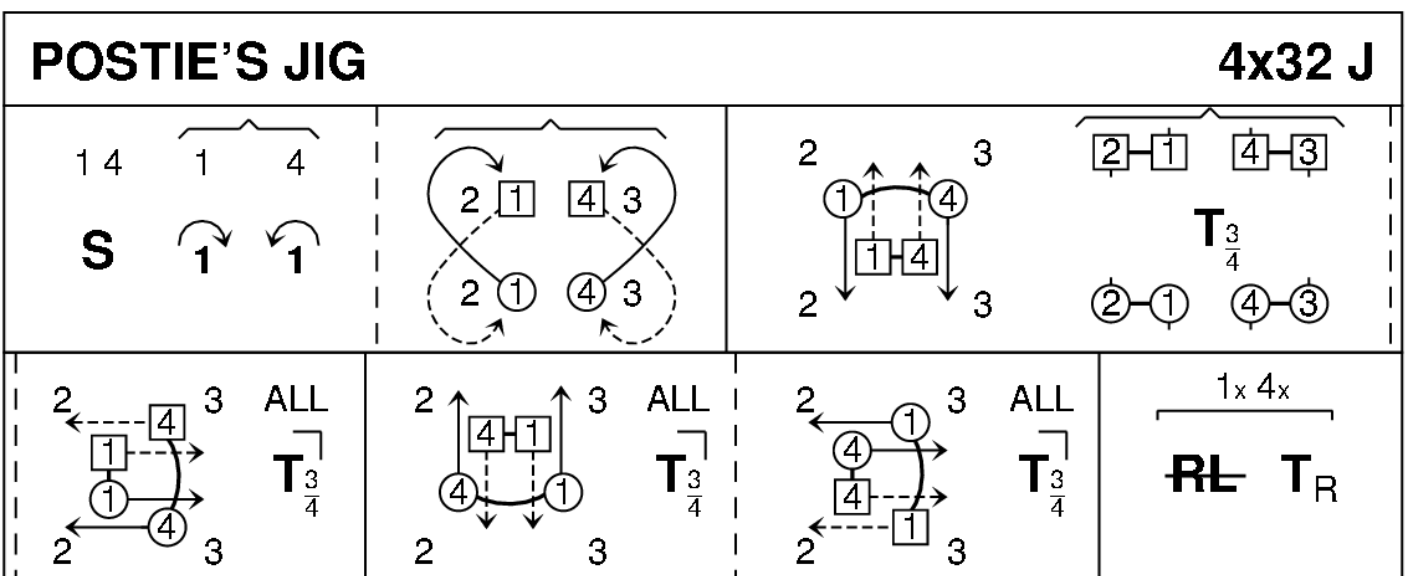

Roy Clowes, Ormskirk 5, RSCDS Thirty Popular Dances Vol 2

4C/4C longwise set.

**12- GANG THE SAME GATE (S8x32) 3C (4C set) Milton Levy RSCDS Book 36**

1- 8 1s cross RH and cast down to 3rd place, cross RH and cast up to 2nd place on own sides

9-16 1s set advancing to partner and turn 1st corner 2H to face 2nd corner, 1s dance ½ diagonal reel of 4 ending M between top couple facing down and L between bottom couple facing up

17-24 1s set advancing to partner and turn 4th corner (position) 2H to face own 1st corner (position), 1s dance ½ diagonal reel with 1st corners ending in 2nd place opposite sides

25-32 3s+1s+2s set and link for 3 twice. 213

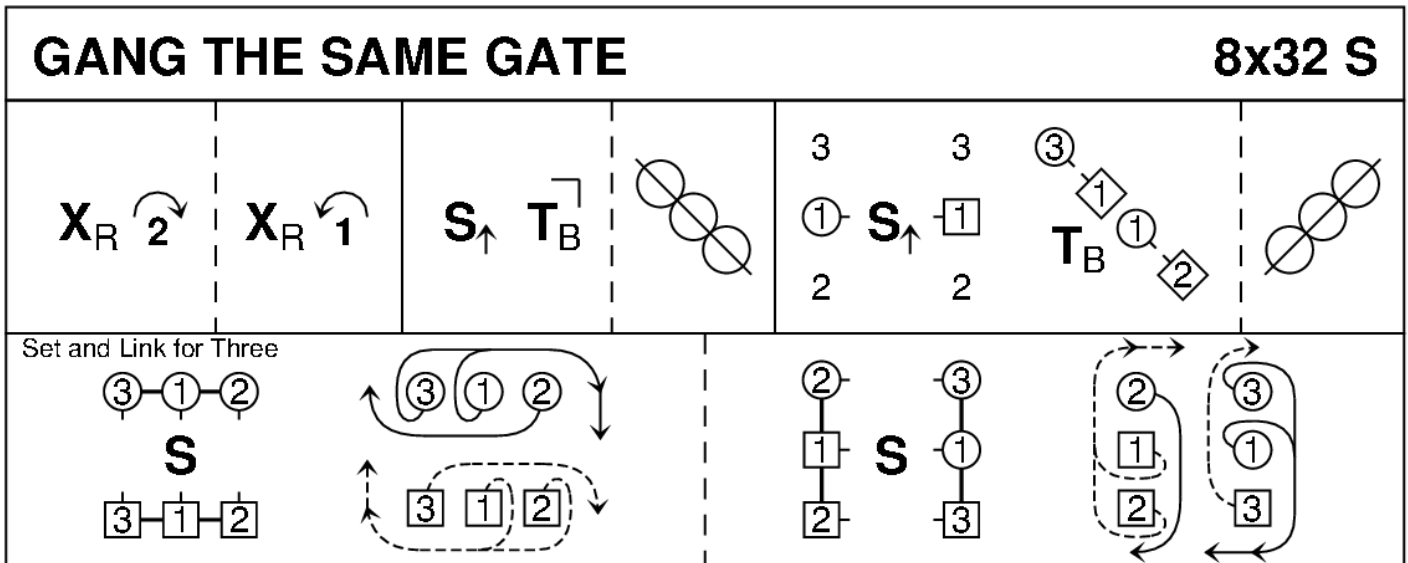

Milton Levy, RSCDS Book 36.4

3C/4C longwise set.

**13- THE GOLDEN SUN OF EARLY SPRING (J8x32) 3C (4C set) Victor Lanvin, 2019, Paris Book Vol 2**

1- 8 1s (+2s who dance up to follow) lead down ; 2s (+1s following) lead up to 1pl **while** 1s following cross to 2pl centre BtoB facing opposite sides (2,1x,3)

9-16 1s dance DT finishing back to back

17-24 1s cast off, meet, lead up to top, cross and cast off to 2nd place

25-32 1s+3s dance R&L

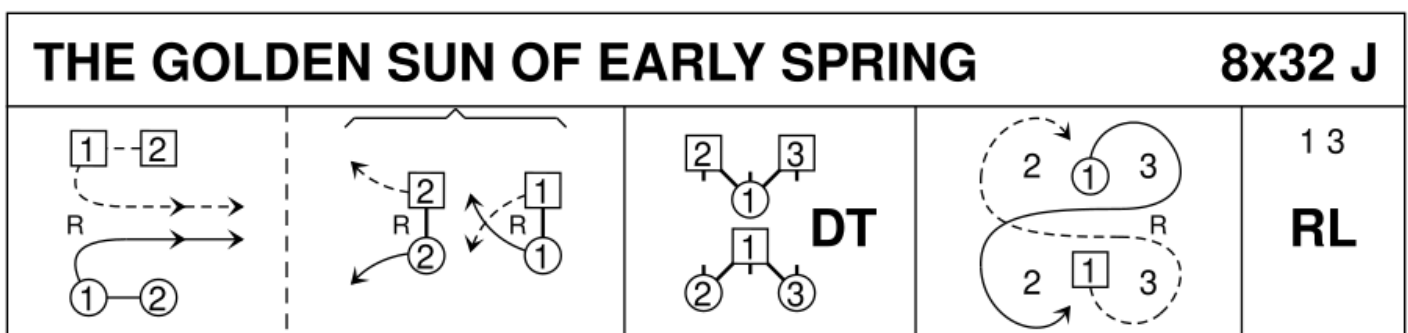

Victor Lanvin, 2019, Paris Book Vol 2





3C/4C longwise set.

**14- DER ABSACKER (R8x32) 3C (4C set) Kenton Stutz, 2016 The Firewood Collection**

1- 8 1s+2s set, dance ½ RH across; Set again, 2s cross LH back to own side as 1s turn LH to face 1st corners  
 9-16 1s turn 1st corners RH, pass RSh; 1s turn 2nd corners RH, dance round partner RSh to face 1st corner again (corners loop into place or "twirl")

17-24 1s set to 1st corner, dance RSh round partner to face 2nd corner; 1s set to 2nd corner, dance RSh round partner to 2nd place own side

25-32 2s+1s+3s circle 6H round and back

DER ABSACKER			8x32 R	
1 2	2x 1x 2x 1x			
S RA	S X <sub>L</sub> T <sub>L</sub> <sup>3/4</sup>	T <sub>R</sub>  T <sub>R</sub> 	S  S 	6

Kenton Stutz, 2016, The Firewood Collection

3C/4C longwise set.

**15- VALSE A MARTIN (W32x4) 32 Bar Waltz for 1 Couple, deviser unknown, Meandre Reel 2023**

1-4 In Allemande Hold, all dance with partner 4 advancing waltz steps, starting Left Foot

5-8 Still in Allemande hold, all dance : Step on Left Foot (1bar), Point Righ Foot to the Right (1 bar) Step Right Foot to the Left in front of left foot (1 bar), Point Left Foot to the left (1 bar)

9-12 Still in Allemande hold, all dance backwards with partner 4 Waltz Steps, starting with Left foot

13-16 Still in Allemande hold, all dance : one step advancing on Left Foot (1bar) Point Right Foot to the right (1bar) Step Right Foot to the left (1 bar) quarter turn pulling back RSH to end both feet joined (1 bar)

17-24 Still in Allemande hold but Lady with back to partner, 2 slow slip steps to the left (2 bars), then to the right (2 bars). Then the Man has his partner turn waltzing under his arm, having her advancing and turning slowly, while man waltzes advancing following his partner

25-32 In ballroom hold, 8 bars of normal waltz

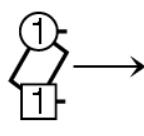
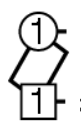
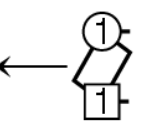
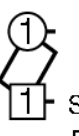
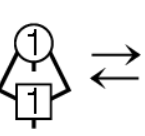
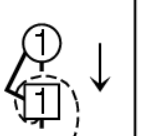
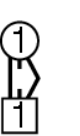
VALSE À MARTIN			32 W			
 Start with left foot	 Step Left Point R foot R Step R foot to L Point L foot L	 Start with left foot	 Step Left Point R foot R Step R foot to L Pivot 1/4 right	 Slip Step		 Waltz

Unknown, <https://my.strathspey.org/dd/dance/21756/>

1C/1C .